

Ma

KEY STAGE

3

TIER

6–8

2001

Mathematics test

Paper 1

Calculator not allowed

Please read this page, but do not open the booklet until your teacher tells you to start. Write your name and the name of your school in the spaces below. If you have been given a pupil number, write that also.

First name _____

Last name _____

School _____

Pupil number

--	--	--	--	--	--

Remember

- The test is 1 hour long.
- You **must not** use a calculator for any question in this test.
- You will need: pen, pencil, rubber and a ruler.
- Some formulae you might need are on page 2.
- This test starts with easier questions.
- Try to answer all the questions.
- Write all your answers and working on the test paper – do not use any rough paper.
- Check your work carefully.
- Ask your teacher if you are not sure what to do.

For marker's
use only

Total marks

--

Instructions

Answers



This means write down your answer or show your working and write down your answer.

Calculators



You **must not** use a calculator to answer any question in this test.

Formulae

You might need to use these formulae.

Trapezium

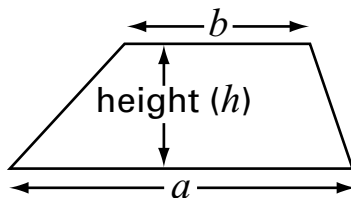

$$\text{Area} = \frac{(a + b)}{2} \times h$$

Prism

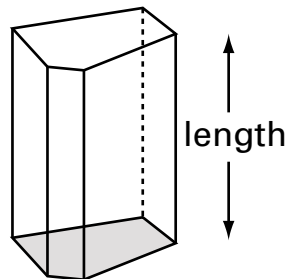

$$\text{Volume} = \text{area of cross-section} \times \text{length}$$

1. There are **60 pupils** in a school.
6 of these pupils wear glasses.

(a) The pie chart is not drawn accurately.

What should the angles be?
 Show your working.

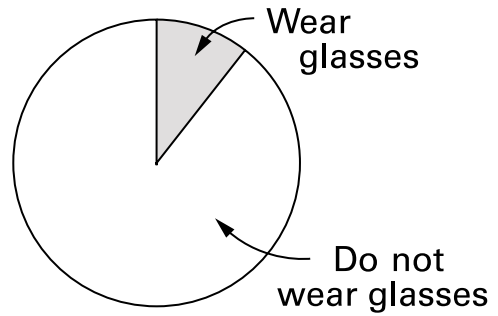

.....
° and°

 2 marks

(b) Exactly **half** of the 60 pupils in the school are boys.

From this information, what **percentage of boys** in this school **wear glasses**?
 Tick (✓) the correct box below.



5%	<input type="checkbox"/>	6%	<input type="checkbox"/>	10%	<input type="checkbox"/>
20%	<input type="checkbox"/>	50%	<input type="checkbox"/>	not possible to tell	<input type="checkbox"/>

.....
 1 mark



2. Ali, Barry and Cindy each have a bag of counters.
They do not know how many counters are in each bag.
They know that

Barry has **two more** counters than Ali.

Cindy has **four times as many** counters as Ali.

- (a) Ali calls the number of counters in her bag a

Write **expressions using a** to show the number of counters in Barry's bag and in Cindy's bag.

Ali's bag

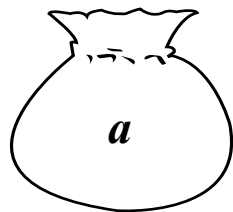

Barry's bag

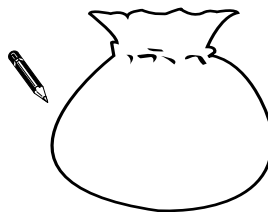

Cindy's bag

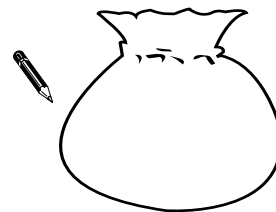

.....
1 mark

- (b) Barry calls the number of counters in his bag b

Write **expressions using b** to show the number of counters in Ali's bag and in Cindy's bag.

Ali's bag

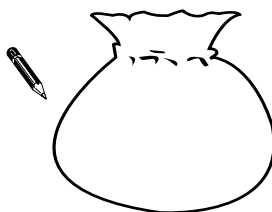

Barry's bag

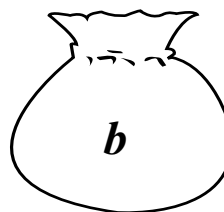

Cindy's bag

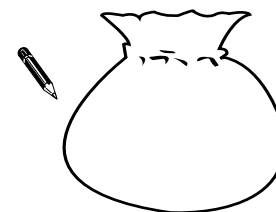

.....
.....
2 marks

(c) Cindy calls the number of counters in her bag c

Ali's bag

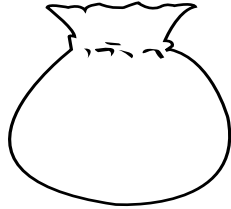

Barry's bag

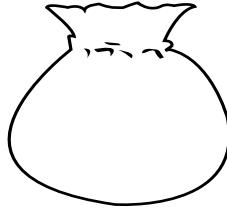

Cindy's bag

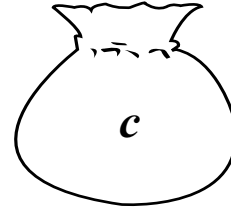

Which of the expressions below shows the number of counters in **Barry's** bag?

Circle the correct one.



$$4c + 2$$

$$4c - 2$$

$$\frac{c}{4} + 2$$

$$\frac{c}{4} - 2$$

$$\frac{c + 2}{4}$$

$$\frac{c - 2}{4}$$

.....
1 mark



3. The diagram shows two isosceles triangles inside a parallelogram.

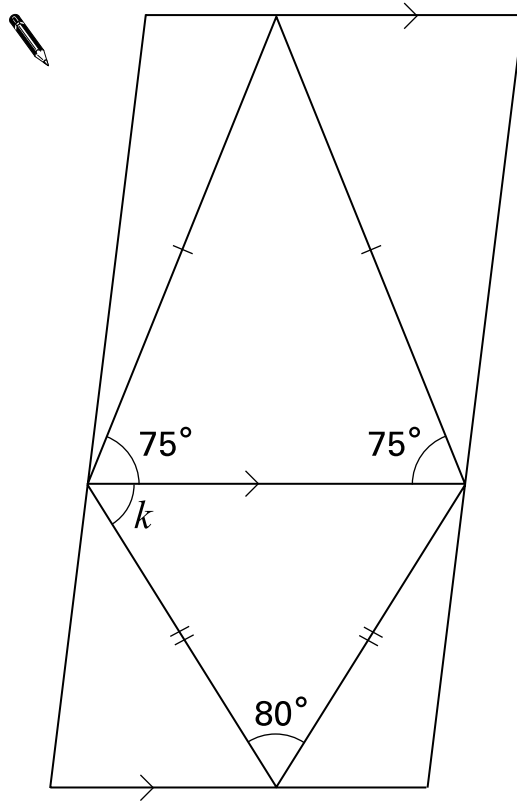

Not drawn accurately

- (a) On the diagram, mark another angle that is 75°

Label it 75°

.....
1 mark

- (b) Calculate the size of the angle marked k

Show your working.

.....

.....
2 marks



Now look at the triangle drawn on the straight line PQ

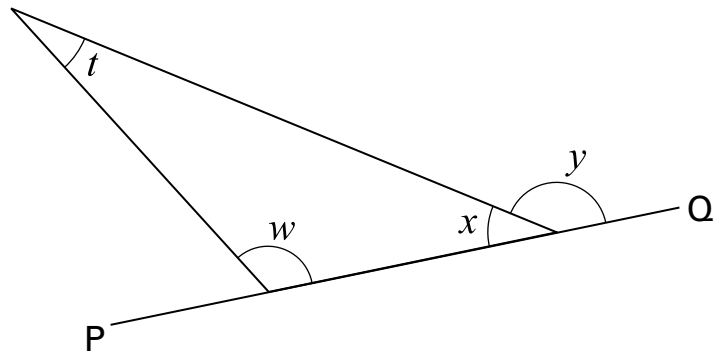

(c) Write x in terms of y



.....
1 mark

(d) Now write x in terms of t and w



.....
1 mark

(e) Use your answers to parts (c) and (d) to show that $y = t + w$



.....
1 mark



4. Here are three number cards.
The numbers are hidden.

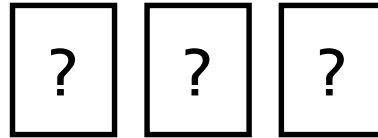

The **mode** of the three numbers is **5**
The **mean** of the three numbers is **8**

What are the three numbers?
Show your working.



.....
..... / /
.....
2 marks

5. On a farm **80** sheep gave birth.
30% of the sheep gave birth to two lambs.
The rest of the sheep gave birth to just one lamb.
In total, how many lambs were born?
Show your working.



.....
..... lambs
.....
2 marks

6. Two parts of this square design are shaded black.
Two parts are shaded grey.

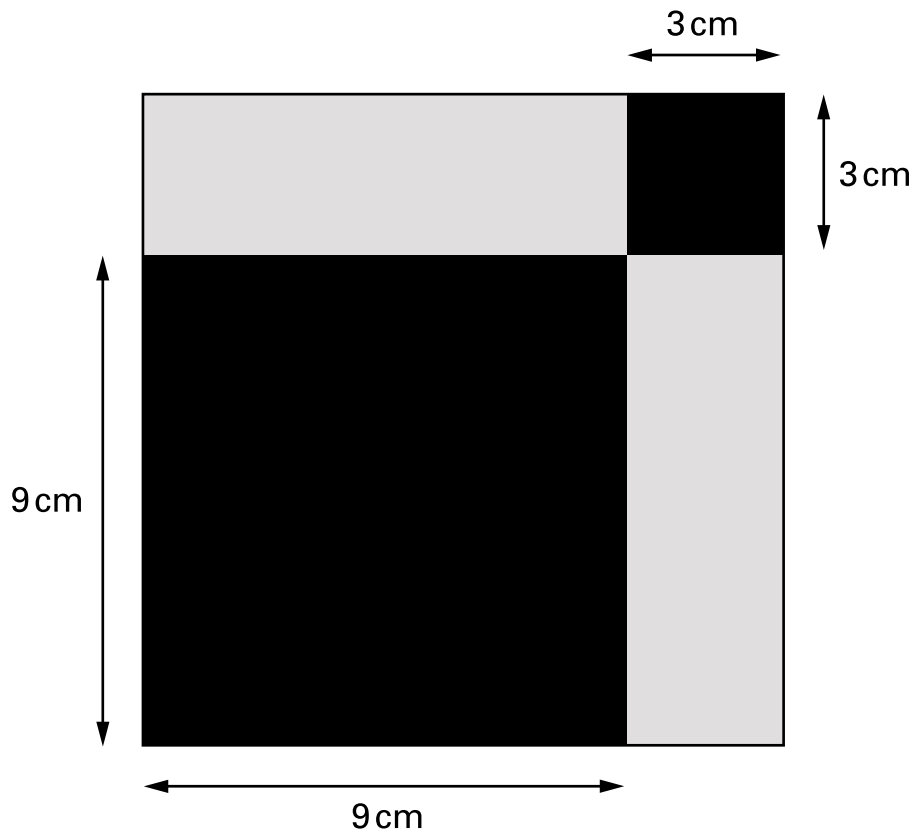

Show that the ratio of black to grey is **5 : 3**



.....

.....
2 marks



7. (a) Solve this equation.

$$7 + 5k = 8k + 1$$



$$k = \dots\dots\dots$$

.....
1 mark

(b) Solve these equations. Show your working.

$$10y + 23 = 4y + 26$$



$$y = \dots\dots\dots$$

.....
.....
2 marks

$$\frac{3(2y + 4)}{14} = 1$$



$$y = \dots\dots\dots$$

.....
.....
2 marks

8. (a) Look at these numbers.

1^6	2^5	3^4	4^3	5^2	6^1
-------	-------	-------	-------	-------	-------

Which is the **largest**?



.....

.....
1 mark

Which is equal to 9^2 ?



.....

.....
1 mark

(b) Which **two** of the numbers below are **not** square numbers?

2^4	2^5	2^6	2^7	2^8
-------	-------	-------	-------	-------



..... and

.....
1 mark



9. (a) m is an **odd** number.

Which of the numbers below must be even, and which must be odd?

Write 'odd' or 'even' under each one.



$2m$

m^2

$3m - 1$

$(m - 1)(m + 1)$

.....

.....
2 marks

(b) m is an **odd** number.

Is the number $\frac{m+1}{2}$ odd, or even, or is it not possible to tell?

Tick (✓) the correct box.



odd	
-----	--

even	
------	--

not possible to tell	
----------------------	--

Explain your answer.



.....
1 mark

10. (a) Alan has a guessing game on his computer.
He estimates that the probability of **winning** each game is **0.35**

Alan decides to play **20** of these games.

How many of these games should he expect to **win**?



.....

.....
1 mark

- (b) Sue played the same computer game.

She won **12** of the games she played, and so
she estimated the probability of winning each game to be **0.4**

How many games did Sue play?

Show your working.



.....

.....
2 marks

- (c) The manufacturers of another guessing game claim that the probability of winning each game is **0.65**

Karen plays this game **200** times and **wins 124** times.

She says: 'The manufacturers must be wrong'.

Do you agree with her? Tick (✓) Yes or No.



Yes No

Explain your answer.



.....
1 mark



11. Here are six different equations, labelled A to F

A	$y = 3x - 4$	B	$y = 4$	C	$x = -5$
D	$x + y = 10$	E	$y = 2x + 1$	F	$y = x^2$

Think about the graphs of these equations.

(a) Which graph goes through the point **(0, 0)**?



.....

.....
1 mark

(b) Which graph is **parallel** to the y -axis?



.....

.....
1 mark

(c) Which graph is **not a straight line**?



.....

.....
1 mark

(d) Which **two** graphs pass through the point **(3, 7)**?



..... and

.....
2 marks

(e) The diagram shows the graph of the equation $y = 4 - x^2$

What are the coordinates of the points where the graph of this equation meets the graph of equation E ?

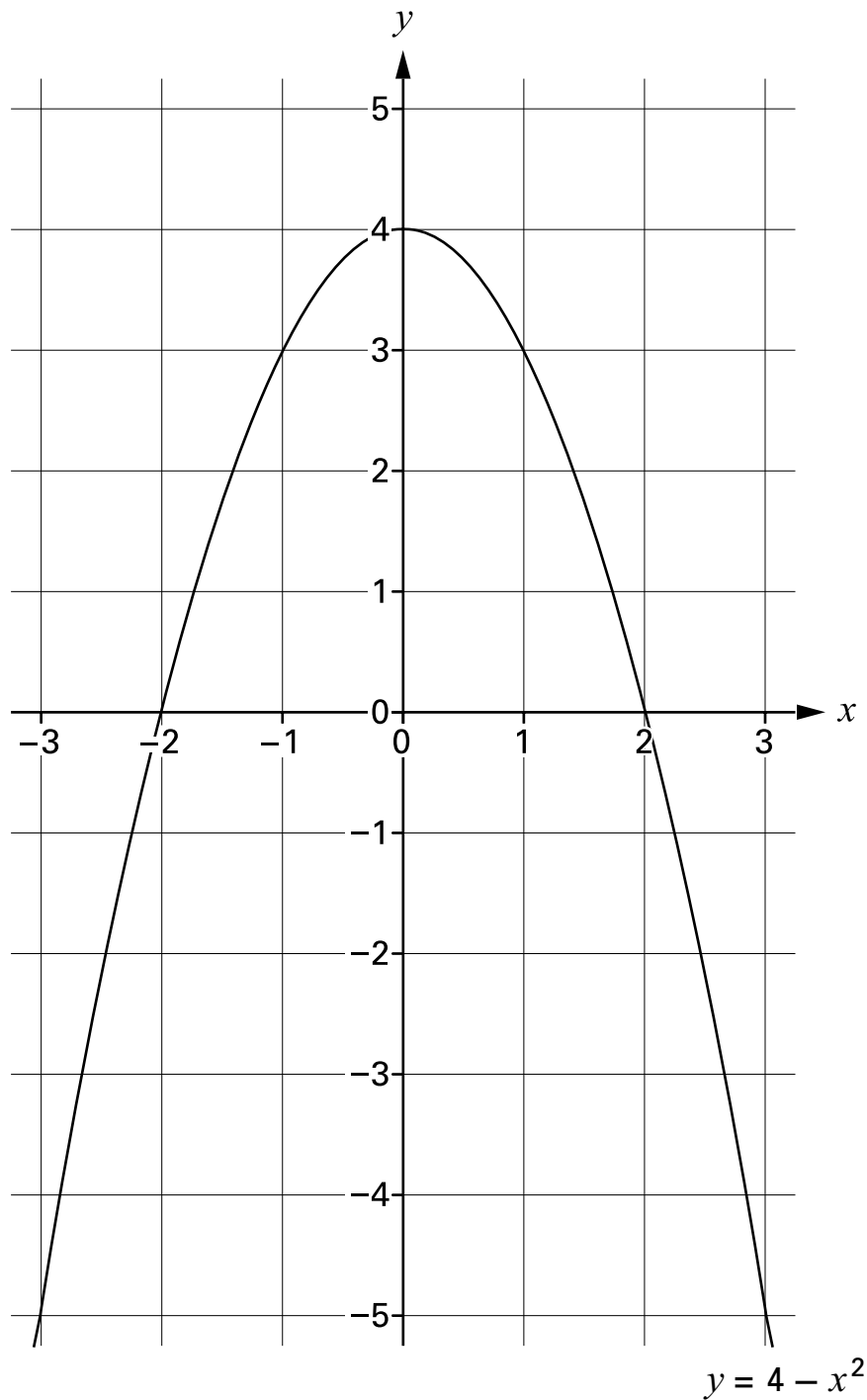

(,) and (,)

.....

.....

3 marks



12. Equations may have different numbers of solutions.

For example: $x + 2 = 7$ has only one solution, $x = 5$

but $x + 1 + 2 = x + 3$ is true for all values of x

Tick (✓) the correct box for each algebraic statement below.



	Correct for no values of x	Correct for one value of x	Correct for two values of x	Correct for all values of x
$3x + 7 = 8$				
$3(x + 1) = 3x + 3$				
$x + 3 = x - 3$				
$5 + x = 5 - x$				
$x^2 = 9$				

.....

.....

.....
3 marks

13. The diagram shows five triangles. All lengths are in centimetres.

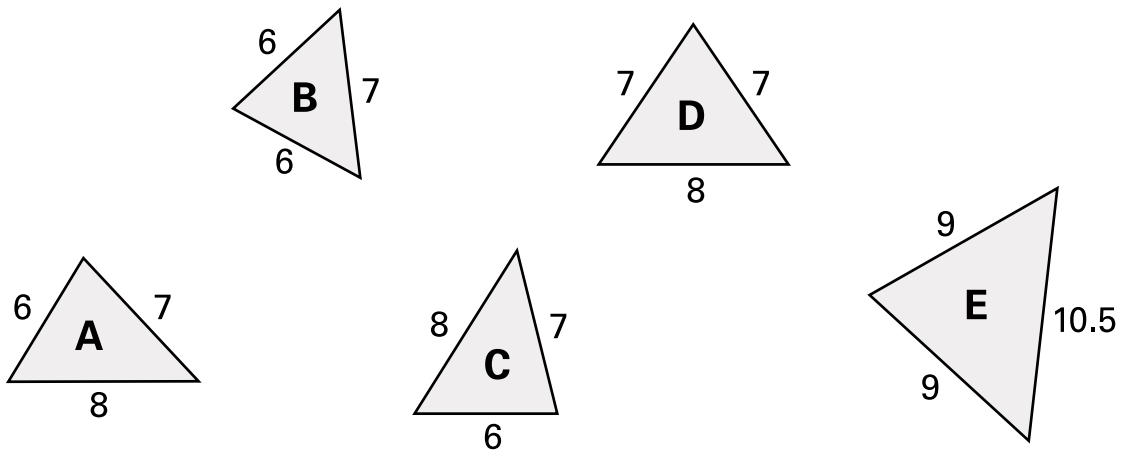

(a) Write the letters of two triangles that are **congruent** to each other.

 and

Explain how you know they are congruent.



.....
1 mark

(b) Write the letters of two triangles that are mathematically **similar** to each other but **not** congruent.

 and

Explain how you know they are mathematically similar.



.....
1 mark



14. The first 'Thomas the Tank Engine' stories were written in 1945.
In the 1980s, the stories were rewritten.

The cumulative frequency graph shows the numbers of words per sentence for one of the stories.

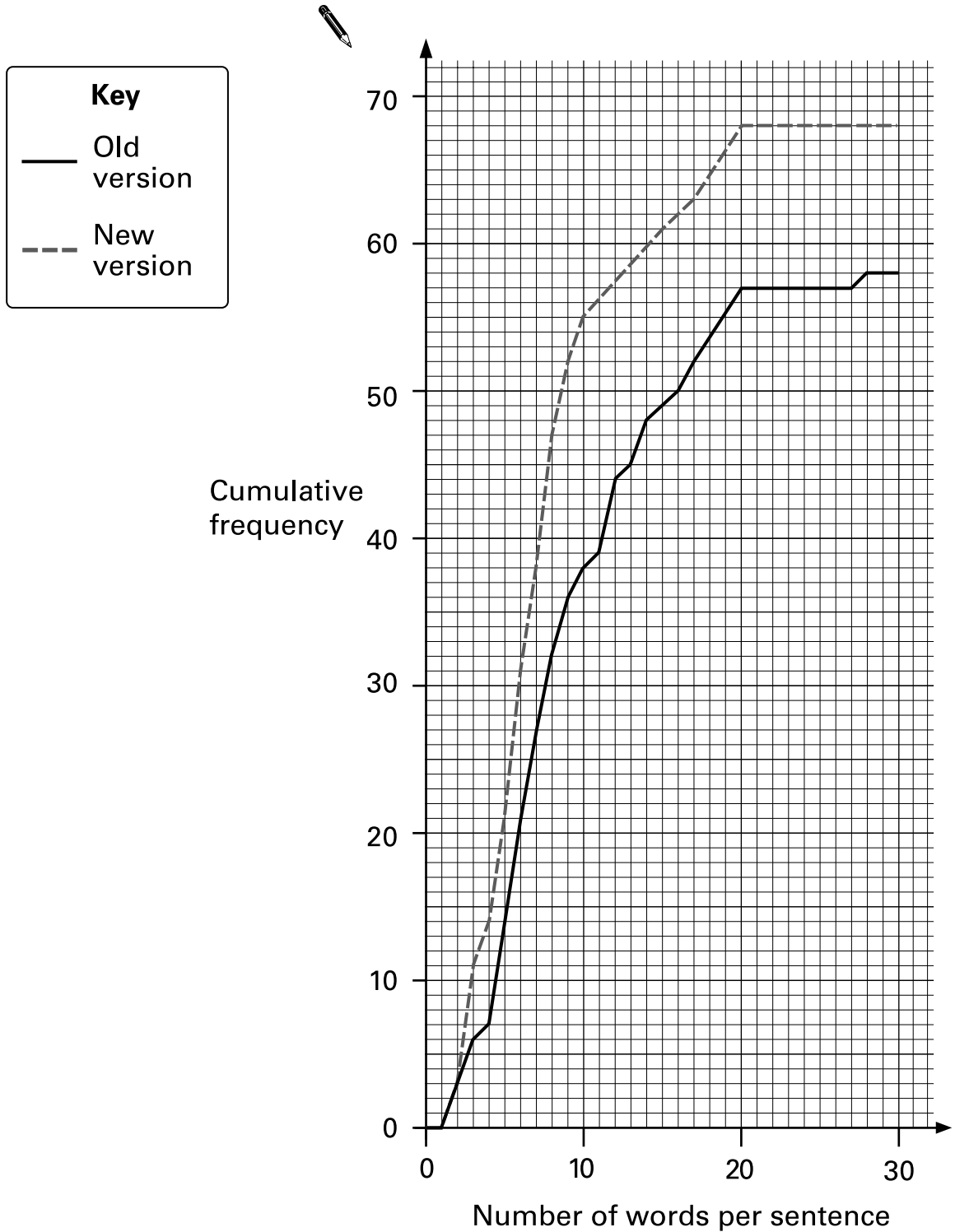

There are **58 sentences** in the old version.

There are **68 sentences** in the new version.

- (a) Estimate the **median** number of words per sentence in the old version and in the new version.

Show your method on the graph.



old

.....

.....

new

.....

3 marks

- (b) What can you tell from the data about the number of words per sentence in the old version and in the new version?



.....

1 mark

- (c) Estimate the percentage of sentences in the **old** version that had more than 12 words per sentence.

Show your working.



..... %

.....

2 marks



15. (a) A fair coin is thrown. When it lands it shows heads or tails.

Game: Throw the coin **three** times.

Player **A wins** one point each time the coin shows a **head**.

Player **B wins** one point each time the coin shows a **tail**.

Show that the probability that player A scores three points is $\frac{1}{8}$



.....
1 mark

- (b) What is the probability that player B scores exactly **two** points?
Show your working.



.....
.....
2 marks

16. $\frac{1}{2500}$ is equal to **0.0004**

(a) Write 0.0004 in standard form.



.....

.....
1 mark

(b) Write $\frac{1}{25000}$ in standard form.



.....

.....
1 mark

(c) Work out $\frac{1}{2500} + \frac{1}{25000}$

Show your working, and write your answer in standard form.



.....

.....
2 marks



BLANK PAGE

END OF TEST

